

## Table of Contents

Safety Instructions & Warnings	1
What's Included	2
Orbit IC Fixture Installation	3
Cable Connections	4
Remote & Controller Overview	5
Controller Programming	7
Warranty & Safety Warnings	12

**Thank You!**  
 For purchasing our Orbit IC LED.  
 Please read all instructions before  
 getting in the LOOP!

## Safety Instructions & Warnings

**IMPORTANT: Please refer to additional safety warnings on last page.**

- Carefully examine light fixture, wires and all components before and after installation. Ensure there is no damage or water on any components BEFORE plugging into a GFCI wall outlet.
- NEVER plug in a wet cord. Always unplug with dry hands for any maintenance or service.
- Ensure 12VDC UL® transformer is plugged into a GFCI approved outlet with a drip loop for each light fixture. If using eFlux wave or flow pumps, ensure a 24VDC UL® transformer is used with drip loop.
- Turn controller OFF and disconnect lights and pumps from power & GFCI outlet before performing service.
- Never look directly into the LEDs.
- Never run pumps dry or out of water.
- Follow all safety instructions for any eFlux wave or flow pumps or additional accessory add-ons.
- eFlux wave pumps create a tremendous amount of water flow. Do not install pump where the strong current can harm corals or animals.
- eFlux wave pumps can produce powerful waves in both wave and surge modes. Ensure your aquarium is designed for wave pumps and ensure pumps are mounted low enough not to push water out of the aquarium tank.
- Ensure light fixture is kept clean of any saltwater or salt creep. Fixture is IP65 rated for water splashing but must be kept clean of water, moisture, salt creep and/or any mineral deposits.

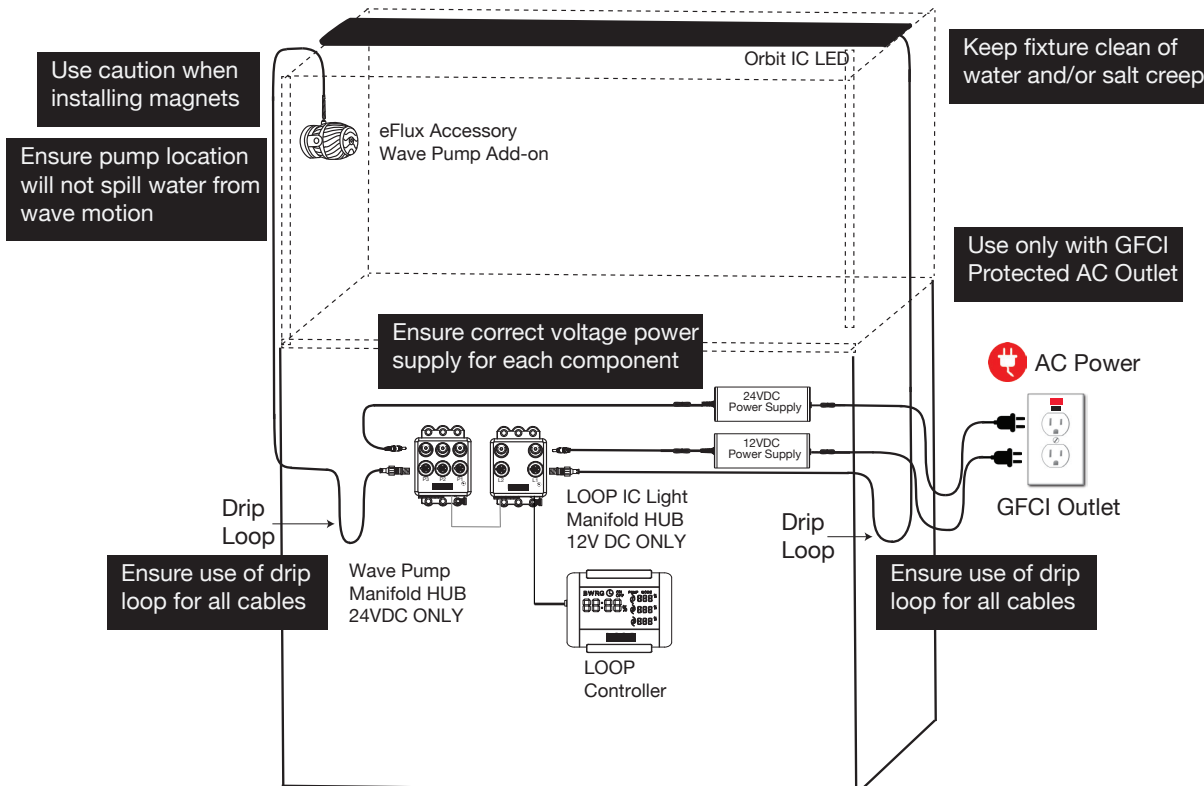

## Additional Help

For additional installation & operating instructions and videos, visit our website at [www.current-usa.com](http://www.current-usa.com)

## What's Included

Each Orbit IC LED lighting system includes:

Item	Description	Quantity
A	Orbit IC LED Light Fixture	1
B	Adjustable Docking Mounts (pre-installed)	2
C	12V DC Transformer, UL® Listed	1
D	Light HUB Manifold w/4 Silicone Covers	1
E	Light HUB Mounting Bracket w/2 Screws	1
F	LOOP LED Light & Pump Controller	1
G	LOOP Controller Bracket w/2 Screws	1
H	Orbit IC Wireless Remote Control	1
J	IR Infrared Sensor	1
L	Cable Wraps	3

### Note:

If your Orbit IC LED is missing any components, please contact us directly at [www.current-usa.com](http://www.current-usa.com).

**DO NOT RETURN TO RETAILER**

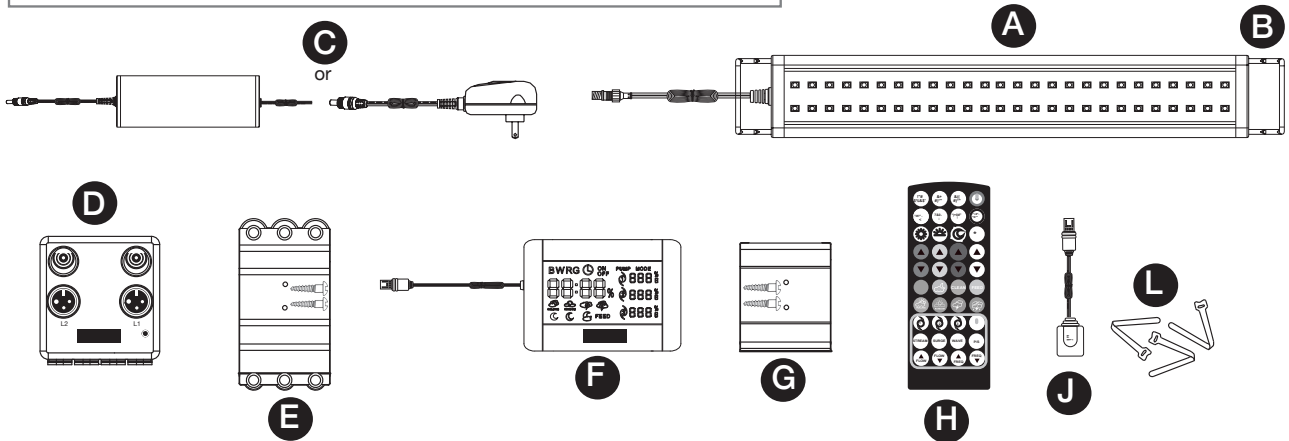

## Optional Accessories

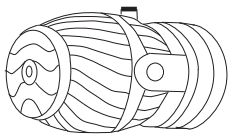
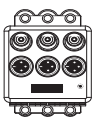

### Accessory Wave Pumps

- #1685 EFlux Wave Pump Manifold (connects up to 3 wave pumps)
- #6004 Accessory Wave Pump 660 GPH
- #6005 Accessory Wave Pump 1050 GPH
- #6006 Accessory Wave Pump 2100 GPH

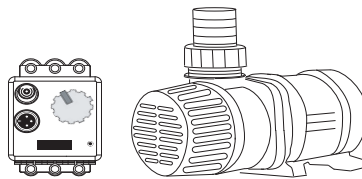

### Controllable DC Flow Pumps

- #6009 EFlux DC Flow Pump 1050 GPH
- #6010 EFlux DC Flow Pump 1900 GPH
- #6011 EFlux DC Flow Pump 3170 GPH

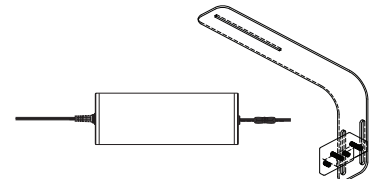

### Orbit IC Accessories

- #4193 Orbit Adjustable Tank Mount
- #4197 LOOP Controller Hinge Mount System
- #5076 12VDC 72W Transformer

## Orbit IC LED Light Fixture Installation

### Fixture Installation

**Step 1.** Unpack light fixture and components. Remove any plastic film on light fixture (A).

**Step 2.** Slide the adjustable docking legs (B) on the side of the light fixture (A) to match the length of your aquarium. (Refer to Orbit Adjustable Tank Mounting Bracket or Orbit Hanging Kit instructions if using those instead of sliding docking mounts.)

**Step 3.** Set fixture on aquarium and ensure docking legs fit snug on edges of aquarium.

### INSTALLING LOOP IC CONTROLLER AND IC LIGHT MANIFOLD HUB

**Step 4.** Choose a location underneath your aquarium cabinet free of excessive moisture and/or saltwater creep. Note: If you want the LOOP IC Controller (F) outside cabinet, ensure the mounting location is 8-12” away from where the IC Light Manifold HUB (D) will be mounted.

**Step 5.** Using included wood mounting screws, mount the IC Light Manifold HUB mounting bracket (E) and LOOP IC Controller bracket (G) to stand. Slide IC Light Manifold HUB (D) and LOOP IC Controller (F) into each bracket.

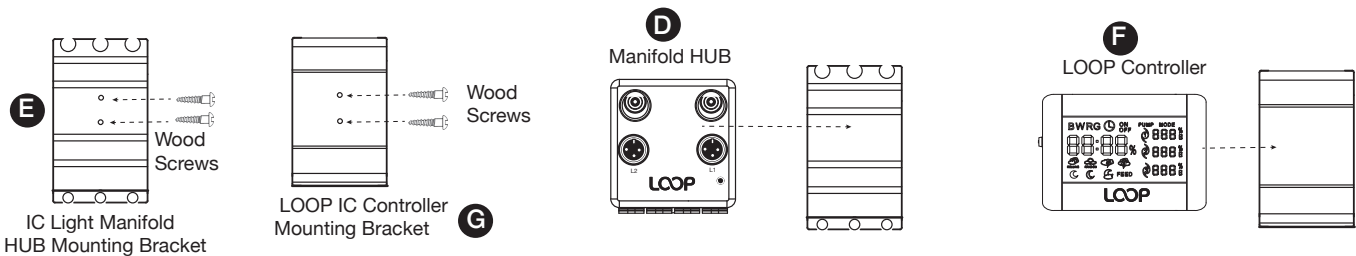

**Step 6.** Remove silicone caps from L1 light #1 DC input and L1 light #1 connection. Attach caps to IC Light HUB mounting bracket (E) for safe storage (see diagram on right.) Keep other silicone caps in place if not in use.

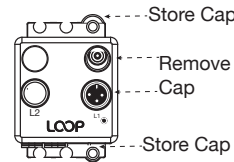

**Step 7.** (Optional) An IR receiving sensor is located on the front of the LOOP IC Controller. The IR sensor is what receives control and on-demand command signals from the wireless remote. If you mount your LOOP IC Controller under your stand, an additional remote IR sensor (J) is included. To mount sensor, unwrap cable and attach the IR sensor to your stand using the stick tape. Ensure cable can reach IC light manifold HUB (D).



### CABLE CONNECTIONS

#### Important:

Before connecting all components together, please review the following specifications in regards to the IC Light Manifold HUB (D).

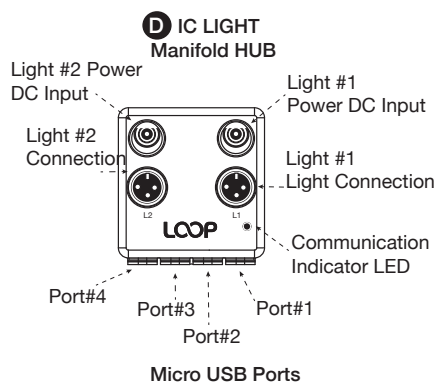

#### Specifications:

Light DC Inputs:  
Voltage: 12VDC  
Max. DC Input per channel: 72w@12VDC  
Max. DC Output per channel: 60w@12VDC

#### Light Connections:

L1 = Light #1  
L2 = Light #2

#### Micro USB Ports:

Port#1= LOOP IC Controller  
Port#2= Communications  
Port#3= Communications  
Port#4= Communications

## Cable Connections

**Step 8.** Connect cables in the following order:

- A** Connect LOOP Controller microUSB cable into Port#1 on bottom of IC Light Manifold HUB
- B** Connect IR Sensor micro USB cable into Port#2 on bottom of IC Light Manifold HUB (optional)\*
- C** Connect Orbit IC LED light into L1 Light Connection on front of IC Light Manifold HUB
- D** Connect 12V DC transformer cable into L1 Light Power DC input on front of IC Light Manifold HUB

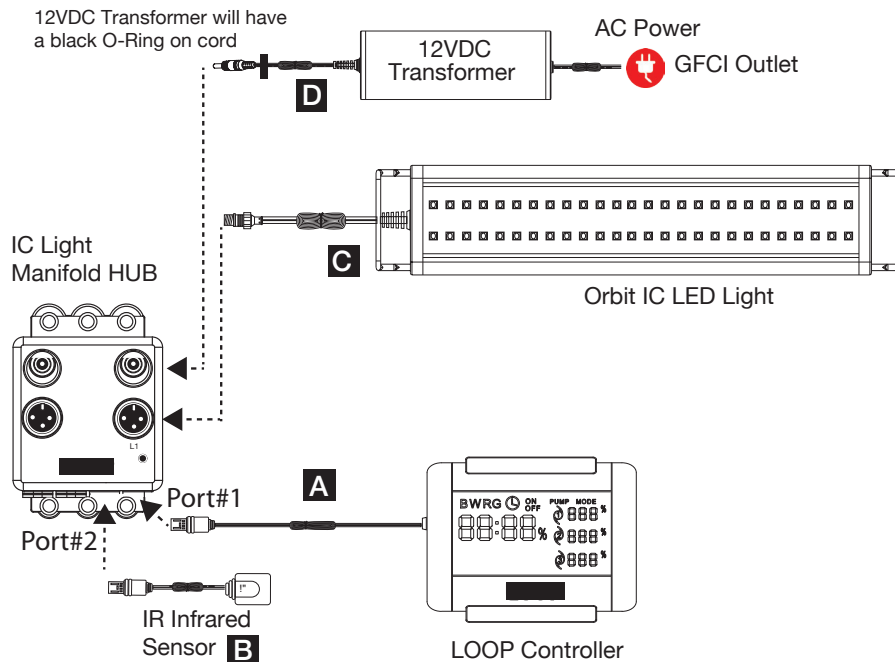

Page 3

\* NOTE: The LOOP Controller has an integrated IR sensor on the front display. If mounting the controller outside your cabinet, the use of the IR Infrared Sensor B is not required. If you wish to mount the LOOP controller inside your cabinet, the remote IR sensor can be mounted in a discrete location outside your stand.

**Step 9.** Plug 12V DC transformer into GFCI outlet. Communication LED indicator light on IC light manifold HUB will turn BLUE.

**Step 10.** Use velcro cable wraps (L) to safely store excess cables.

**Step 11.** Remove clear plastic tab from battery compartment on Orbit IC remote control (H).

**Step 12.** Press Main Power key to turn Orbit IC LED light ON.

**Step 13.** Follow programming steps on the following pages to set the LOOP IC Controller clock and begin operation.



## LOOP IC Remote Control Overview



- Light Power ON/OFF** - press to turn light fixture and Main IC Controller on or off
- Set Time of Day** - press to set the 24:00 clock/current time of day
- ON TIME** - press to program time light should begin to turn on each day
- OFF TIME** - press to program time light should begin to turn off each day
- HOUR / +** - press to change the Hours or adjust weather forecast % up (+)
- MINUTE / -** - press to change the Minutes or adjust weather forecast % down (-)
- ENTER/RESUME** - press to enter a setting or to re-enter back into normal program
- DAYLIGHT** - press to program color spectrum to run during the Day
- Sunrise/Sunset** - press to program color spectrum to run during sunrise/sunset
- Moonlight** - press to program color spectrum to run during the night
- Memory** - press to program a custom color spectrum (Color Memory)
- Weather** - press to program the daily weather forecast or turn off active weather
- Lock/Unlock** - press to lock settings and all remote functions, press again for 5 seconds to unlock settings and remote functions

### Water Pumps Programming

- Pump 1** - press to program the primary eFlux wave pump
- Pump 2** - press to program secondary eFlux wave pump #2
- Pump 3** - press to program pump #3. NOTE: PUMP#3 is only programmable in STREAM mode (no wave mode)
- Primary/Secondary** - press to designate if Pump 2 is a Primary pump or Secondary (slave to Pump#1)
- Pump Power ON/OFF** - press to all pumps ON or OFF
- Stream Mode** - press to program designated pump into stream/constant flow mode
- Surge Mode** - press to program designated pump into surging (long on/off) flow mode
- Wave Mode** - press to program designated pump into wave (short pulsing) flow mode
- Flow Increase** - press to increase the flow rate/impeller speed of pump from 0-100%
- Flow Decrease** - press to decrease the flow rate/impeller speed of pump from 0-100%
- Frequency Increase** - increases frequency / time interval: Surge/Wave
- Frequency Decrease** - decreases frequency / time interval: Surge/Wave

### Color Spectrum Adjustment

- RGBW Adjustment** - press to adjust Red / Green / Blue / White color spectrums 0-100%

### Dynamic Modes

- Feed Mode** - runs feed program, 10 min duration  
Lights: Remaining in current color mode  
Pumps 1 & 2: reduce flow to 0%  
Pump 3: reduce flow to 0%  
Note: Any EFlux DC Flow Pumps connected to network reduce flow to 30%
- LUNAR** - press to run light lunar mode:  
Blue: 100%, White:0%, Red: 0%, Green: 0%
- Lunar Cloud** - press to run night cloud cover (blue moonlight fades)
- Clean Mode** - runs clean mode: Duration 30 min, White:100%, Red:100%, Green:100%,
- Rolling Clouds** - runs rolling cloud program
- Random Clouds** - runs random cloud program
- Lightning** - runs lightning storm program
- Full Thunderstorm** - runs full thunderstorm program

## LOOP IC Controller Overview

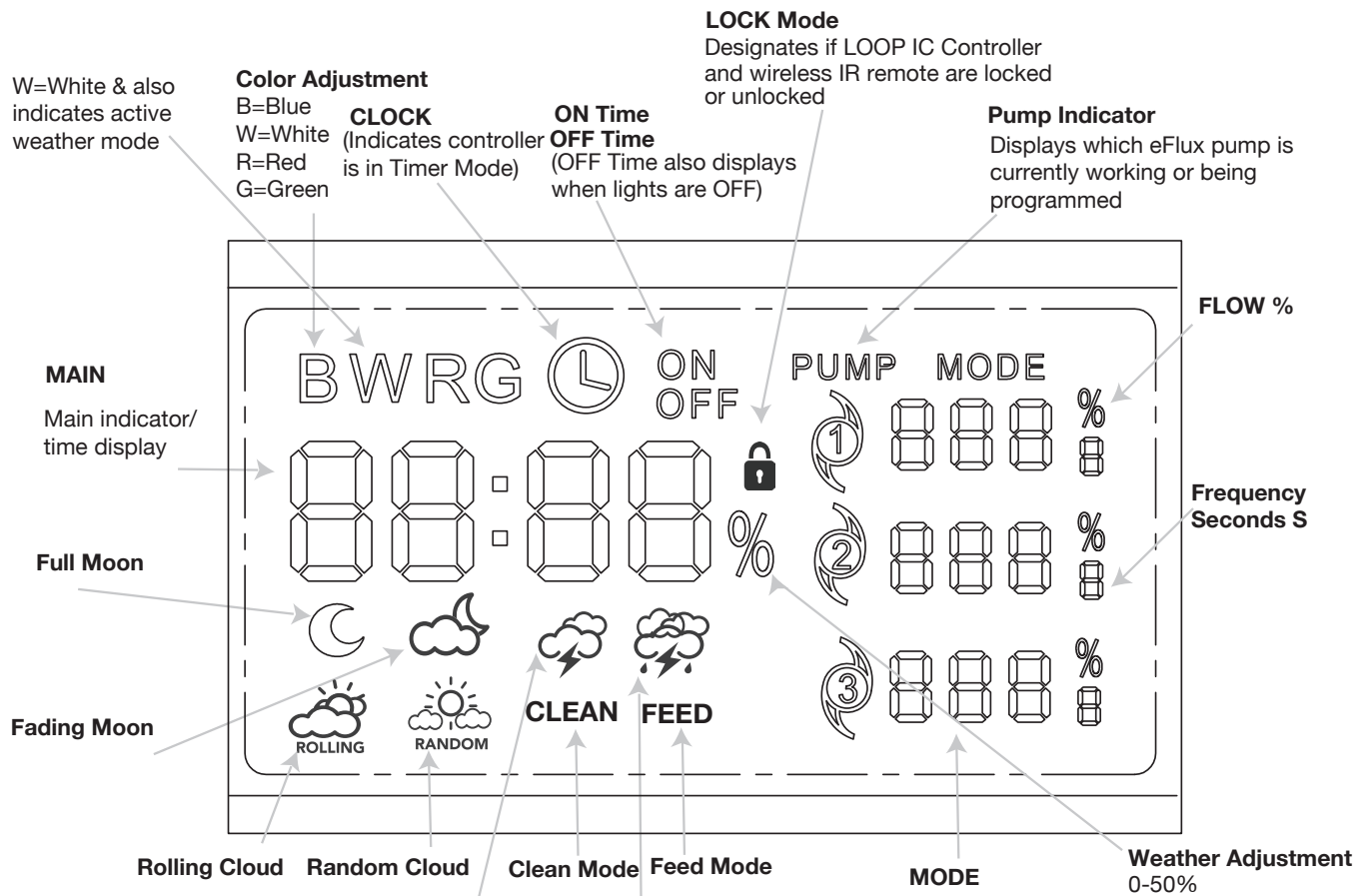

**Note:**  
 LOOP IC Controller backlit display is designed to shut off after 30 seconds.

## Light Cycle Overview

Please review the following light cycle diagram:

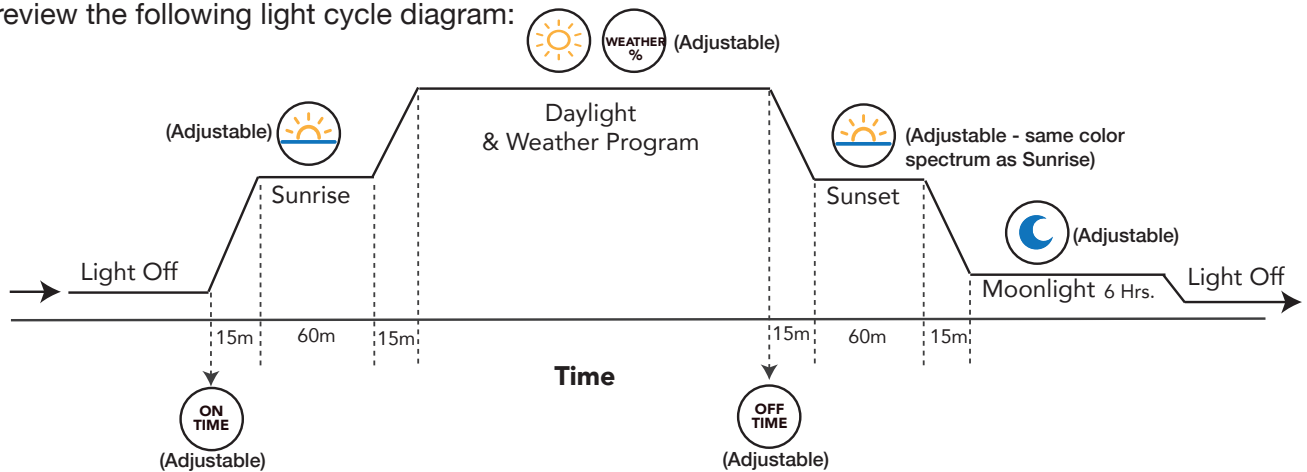

Default Settings - The following settings are pre-programmed into the controller:

- ON Time:** 07:00
- OFF Time:** 18:00
- Pumps:** Stream @100% Flow
- WEATHER:** OFF (Rolling Cloud 30%)
- Daylight Color Spectrum** - W:90% B:100% R:100% G:100%
- Sunrise/Sunset Color Spectrum** - W:5% B:70% R:45% G:20%
- Moonlight Color Spectrum** - W:0% B:10% R:0% G:0%
- Custom Light Color (M):** - W:50% B:100% R:100% G:30%



## LOOP IC Controller Programming

### Turning Lights ON/OFF

Press the Main On/Off key  to turn Orbit IC lights on or off. When off, display will read “OFF.” The LOOP IC Controller will remain on and the backlit display will shut off after 30 seconds.

Note: Turning the Orbit IC LED lights off will not turn the wave pumps off. Pumps will continue to run at their programmed setting. Pumps must be turned on/off separately than IC lights using the pump Main On/Off  key. When pumps are off, display will read “OFF”,



### LOCK & UNLOCK Settings

The integrated LOCK/UNLOCK feature is designed to ensure other IR signals (e.g. TV remote) do not change the settings on your LOOP IC Controller.

To lock all settings in the LOOP IC controller, simply press LOCK  for 5 seconds. “LOC1” will appear on screen along with lock icon.



To unlock and allow the wireless remote control to operate again, press LOCK  for 5 seconds. “LOCO” will appear on screen and lock icon will disappear.



### Programming Settings

#### Setting Current Time of Day

Press SET CLOCK  the CLOCK icon will appear and main digits will blink.

Press HOUR+  and MINUTE-  to adjust the clock to the current time of day. Hours and Minutes will change on the main digits of the display as keys are pressed.

Press ENTER/RESUME to save. The LOOP IC controller will now run the programmed lighting cycle.



Note: LOOP IC Controller uses military time from 00:00 to 24:00. For example, 9:00pm=21:00 hours. On/off times can only be set between the same 00:00 and 24:00 hours.



Main Digits Blink



#### Setting Daily ON/OFF Times

Press ON TIME key  the ON icon will appear on the display and main digits will blink.

Press HOUR+  and MINUTE-  to adjust the clock to the desire ON time. Press ENTER/RESUME to save.



Press OFF TIME key  the OFF icon will appear on the display and main digits will blink.

Press HOUR+  and MINUTE-  to adjust the clock to the desire OFF time.



At any time press ENTER/RESUME  to save.

## LOOP IC Controller Programming

### Programming Daily Weather

#### To Turn Daily Weather Program On/Off

Press Weather % key on wireless remote and hold for 5 seconds. “W” will appear on the LOOP IC Controller screen and the current weather program icon will be displayed on the bottom of the screen and will display during weather cycle.



Press Weather % key again on wireless remote and hold for 5 seconds to turn the weather program off. “W” will disappear from display and your LED light will run its normal photoperiod with no weather patterns.

#### To Program Daily Weather

Press Weather % key , “SET” will display on LOOP IC Controller screen. Choose any of the four weather patterns - Rolling Clouds , Random Clouds , Storm , Full Storm and press to designate as a weather pattern.



Press the Hour + and Minute - keys to change the daily weather forecast % between 10% and 50%.

Press Enter/Resume , the weather program is now programmed and will run automatically throughout the Daylight lighting period based on your weather forecast. (example: Rolling Clouds @ 20% with a 9 hour daylight period, cloud cover program will run 6 times throughout the day for 108 total minutes (18 minutes each time.)

### Programming Color Spectrums

The LOOP IC Controller allows you to program & change the color spectrum for DAYLIGHT, SUNRISE/SUNSET, MOONLIGHT and a CUSTOM color. The color spectrum can be adjusted by changing the intensities of Red, Green, Blue & White (RGBW) and using the designated color arrow keys on the wireless remote. The LOOP IC Controller will display R, G, B, W and the level of each color.

Color Adjustment - Press to adjust Red/Green/Blue/White color spectrums 0-100%



#### To Program DAYLIGHT

Press DAYLIGHT key on wireless remote and “L1” will display on the LOOP IC Controller screen. Use the RGBW keys to change the % intensity. Once the desired color spectrum is achieved, Press and hold the DAYLIGHT key for 5 seconds. The LOOP IC Controller will display “E1” indicating spectrum is saved.



#### To Program SUNRISE/SUNSET

Press SUNRISE/SUNSET key on wireless remote and “L2” will display on the LOOP IC Controller screen. Use the RGBW keys to change the % intensity. Once the desired color spectrum is achieved, Press and hold the SUNRISE/SUNSET key for 5 seconds. The LOOP IC Controller will display “E2” indicating spectrum is saved.



#### To Program MOONLIGHT

Press MOONLIGHT key on wireless remote and “L3” will display on the LOOP IC Controller screen. Use the RGBW keys to change the % intensity. Once the desired color spectrum is achieved, Press and hold the MOONLIGHT key for 5 seconds. The LOOP IC Controller will display “E3” indicating spectrum is saved.



\*\*\*NOTE: YOU MUST press ENTER/RESUME to put the LOOP IC Controller back into timer mode after programming\*\*\*



## LOOP IC Controller Programming

### To Program a CUSTOM Color Spectrum

Press CUSTOM key (M) on wireless remote and “L4” will display on the LOOP IC Controller screen. Use the RGBW keys to change the % intensity. Once the desired color spectrum is achieved, Press and hold the CUSTOM key (M) for 5 seconds. The LOOP IC Controller will display “E4” indicating spectrum is saved.



### On Demand Dynamic Modes

#### Moonlight Modes

Press either Full Moon or Fading Moon on IC wireless remote to activate on-demand moonlight. Program will run 30 minutes then resume into normal programming. To exit on-demand program, press (ENTER/RESUME) on wireless remote.

#### Weather Modes

Press either Rolling Cloud, Random Cloud, Lightning Storm, or Full Storm with Lightning on wireless remote to activate on-demand weather. Program will run 30 minutes, then resume into normal timer programming. To exit On-Demand program, press (ENTER/RESUME).



On-demand icon moonlight or weather icon will display on screen

#### CLEAN Mode

Press CLEAN on wireless remote activate a color spectrum for cleaning the aquarium. Program will run for 30 minutes, then resume into normal timer programming.

To exit on-demand programs at any time, press (ENTER/RESUME).



### eFlux Wave Pump Programming

#### Turning Pumps On/Off

Press the Main On/Off key on wireless remote to turn all of the wave pumps on or off. When turning off, “OFF” will be display on the LOOP IC Controller and each pump icon will be followed by “---”.

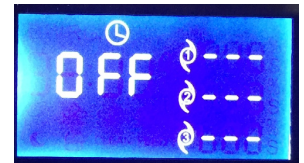

#### Turning Individual Wave Pumps On/Off

To individually turn each wave pump on or off, simply hold the designated pump key for 5 seconds. The individual pump will turn on/off, if off the pump icon will display “OFF” on the LOOP IC Controller.



#### FEED Mode

To set all wave pumps into feed mode, press the FEED Mode key. All eFlux wave pumps (1,2,3) within the LOOP network will stop flowing for 10 minutes and “FEED” will appear on the LOOP IC Controller. After 10 minutes, wave pumps will ramp back into their previous programmed flow setting.



NOTE: Any eFlux DC Flow Pumps within the LOOP network network will ramp down to a 30% flow speed for 10 minutes. After 10 minutes, pumps will ramp back into their previous programmed flow setting.

\*\*Note: Any on-demand Mode, CLEAN mode or FEED mode can be exited at any time by pressing (ENTER/RESUME).

**LOOP IC Controller Programming**
**eFlux Wave Pump Programming**
**Designating Wave Pumps for Programming**

Press the wave pump key on the wireless remote you are choosing to program, the designated pump icon on the LOOP IC Controller will flash and show its current flow program.

**Operational Flow Modes**

There are three modes of water flow available for Pumps 1 and 2; Stream/Steady, Surge/Gyre and Wave/Pulse. Note that Pump 3 is designated as a circulation pump and can only be programmed in Stream/Steady Flow Mode.

**STREAM/STEADY MODE**

When a pump is in Stream/Steady mode, the pump will constantly circulate water at the programmed speed.

Flow rate is adjustable from 0-100% in 10% increments by pressing:

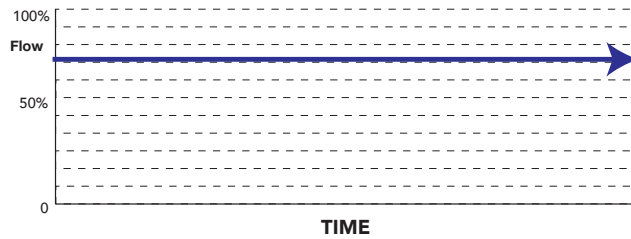
**SURGE/GYRE MODE**

When a pump is in Surge/Gyre mode, the pump will gently ramp up and down to the maximum flow speed based on the frequency (time) programmed. This mode mimics back and forth water surges found in the ocean. See GYRE for using 2 pumps and creating Gyre flow.

Flow rate is adjustable from 0-100% in 10% increments by pressing:



Frequency (timer duration) is adjustable:



Press to decrease time duration of pulse and increase wave motion



Press to increase time duration of pulse and decrease wave motion

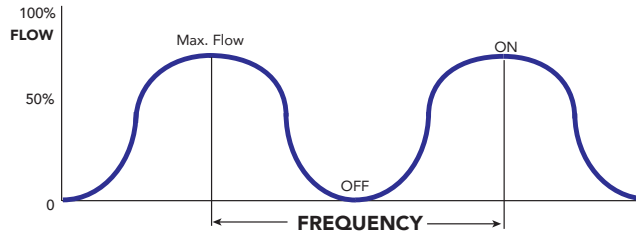

**FREQUENCY (seconds) 10s 15s 20s 25s 30s 40s 50s 70s 80s 90s**

**WAVE/PULSE MODE**

When a pump is in Wave/Pulse mode, the pump will turn on/off, creating a pulsing between the maximum flow and off. This flow simulates waves commonly found on reef crests.

Flow rate is adjustable from 0-100% in 10% increments by pressing:



Frequency (timer duration) is adjustable:



Press to decrease time duration of pulse and increase wave motion



Press to increase time duration of pulse and decrease wave motion

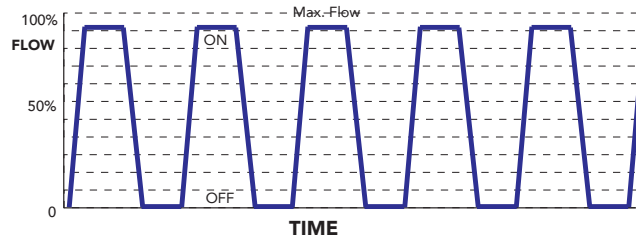

FREQUENCY(seconds)	.3s	.5s	.7s	1s	2s	3s	4s	5s	6s	7s
Pump ON	.3s	.5s	.7s	1s	2s	3s	4s	5s	6s	7s
Pump OFF	.3s	.5s	.7s	1s	2s	3s	4s	5s	6s	7s

## LOOP IC Controller Programming

### Program Flow Mode



Press the FLOW mode key    you wish to run the pump in on the remote. The LOOP IC Controller display will show as follows:

P=Pump  
 1,2,3=indicates the pump being programmed  
 P=Wave/Pulse Mode  
 L=Stream Mode  
 S=Surge Mode

For example:  
 P1-S = Pump #1 Surge Mode  
 P2-L = Pump #2 Stream Mode





### Program Water Flow

Press the increase & decrease flow keys   to adjust the pumps maximum flow rate until the desired flow is reached. Flow rate (between 0-100%) will display on the LOOP IC Controller.



### Program Frequency Setting

If programming the eFlux wave pump in either wave or surge mode, adjust the frequency setting by pressing the increase & decrease frequency keys   until the desired time duration is reached and displayed on the LOOP IC Controller.

The frequency will display on the LOOP IC Controller in seconds.

NOTE: Decreasing frequency increases the time duration between min/max flow. It will appear opposite on the LOOP IC Controller (decreasing frequency will increase the time duration and decrease wave motion.)

Your setting will be automatically be saved into memory after 10 seconds. No keys need to be selected to save settings. You can also press Enter/Resume  at any time to save settings and go to timer program.

### Designating Primary/Secondary Pump

The LOOP IC Controller can run two pumps in opposite flows to create Gyre flow in an aquarium. Pump #1 is the primary wave pump, Pump #2 can be a primary or secondary pump. When pump #2 is designated a secondary wave pump, it will run the opposite Wave/Pulse or Surge mode as Pump #1.

To program Pump #2 as a secondary wave pump, press the P/S key and hold for 5 seconds. The LOOP IC controller will display 2-SL when working as a secondary pump. Press P/S key  for 5 seconds to go back to Pump #2 as a primary pump, LOOP IC controller will display 2-P when running in primary pump mode.

### Reset LOOP IC Controller to Default Settings

If you wish to reset your LOOP IC Controller back to the factory default settings, press the Main Power key  and hold for 10 seconds. All settings in LOOP IC controller will default back and display will read “-ini”.



## Cable Connections

### IMPORTANT WARNINGS | SAVE THESE INSTRUCTIONS

**This is NOT a page of legalese. It contains important safety information that you should read and save for future reference. Remember you can always quickly access instructions for all our products at [www.current-usa.com](http://www.current-usa.com).**

- Never attempt repairs yourself; return the appliance to an authorized service facility for service or discard the appliance.
- Carefully examine the fixture after installation and BEFORE you plug it into the GFCI wall outlet. Be sure there is no water on any part of the light fixture or the timer.
- Never plug in a wet cord. If a plugged in unit or socket does get wet, DON'T touch it. Instead, promptly disconnect the fuse or circuit breaker that supplies power to the fixture. Then, you may unplug the fixture and examine for the presence of water.
- Never operate a fixture that is damaged or malfunctioning, discontinue use immediately and return the appliance to an authorized service facility.
- Close supervision is necessary when any appliance is used by or near children.
- Always unplug the fixture when not in use, before putting on or taking off parts, and before cleaning. Never pull the cord to unplug from the GFCI.
- Do not use the fixture for anything other than intended use. The use of attachments not recommended or sold by the fixture manufacturer may cause an unsafe condition and will void your warranty.
- Do not install or store the fixture where it will be exposed to the weather or to temperatures below 0° Celsius or 32° Fahrenheit.
- Do not operate at temperatures above 50° Celsius or 122° Fahrenheit.
- Ensure the fixture is securely installed before supplying power to the unit.
- Read and observe all the important notices and warnings on the fixture and power cord. **DO NOT REMOVE THE WARNING LABEL.**
- If an extension cord is necessary, a cord with a rating at least 15 amperes should be used. A cord rated for less amperes or watts than the fixture rating may overheat. Care should be taken to arrange the cord so that it will not be tripped over or pulled.
- Do not look directly into the LEDs.
- **Do not install pumps where strong currents can harm animals. Do not install close to sand bed where it can suck/stir sand.**
- Pumps can produce powerful wave action in both wave and surge modes. Ensure your aquarium is designed for wave pumps and ensure pumps are mounted low enough not to push water out of the aquarium tank.
- **Magnet assembly is VERY powerful. Be cautious not to cause injury to fingers.**
- Keep magnets and all accessories out of reach of children.
- Never place magnets or pump near sensitive electronics, sharp objects or other attractive surfaces.
- Do not run pumps dry or out of water.
- Always place spacer between magnets when not in use.
- Always unplug with dry hands for maintenance or servicing.
- Turn all controllers OFF and disconnect power supply before performing any service or maintenance.
- This product MUST be powered by a UL or ETL listed power supply.
- To avoid possible electric shock, power supply MUST be plugged into a GFCI wall outlet installed by a certified electrician in accordance with all local codes. All products must have a drip loop.

### Important Warnings | Drip Loops

Drip Loops should always be used to help prevent water from traveling along the cord and coming into contact with an electrical outlet. Drip loops must always be below the level of the outlet.

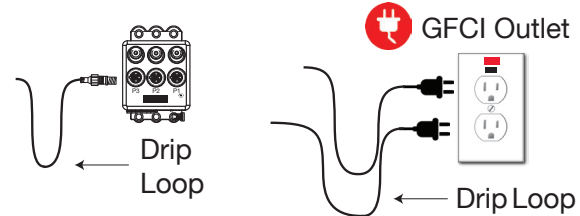

### Current-USA One Year Limited Warranty

This product **MUST** be purchased from an authorized Current-USA reseller. Visit our website for a list of unauthorized resellers. Current USA, Inc. warrants this product against defects in materials and workmanship for **ONE (1) YEAR** from the date of original retail purchase and is none transferable.

Warranty on all Products, including Aquariums, is limited to replacement of the product and does not cover fish loss, personal injury, property loss or direct, incidental or consequential damage arising from the use of this product.

Note: Current-USA, Inc. One-Year Limited Warranty does not cover damage caused by the following: improper installation, saltwater corrosion, electrical surges, or modifications.

If you discover a defect, please see your retail store or point of purchase. Current USA, Inc. will, at it's option, repair or replace the product at no charge to you, provided you return it during the warranty period. A copy of the bill of sale is required as proof of original purchase date in the event the product needs repairs within the warranty period. Please see your dealer for return options and warranty replacement parts. This warranty applies only to products by or for Current USA, Inc. that can be identified by trade name, or logo affixed to them. Current-USA, Inc. does not warrant any products that are not Current-USA, Inc..

This warranty does not apply if the product has been damaged by accident, abuse, misuse or misapplication or if the product has been modified without the written permission of Current-USA, Inc.; or if any Current-USA, Inc. logos have been removed or defaced.

THE WARRANTY AND REMEDIES SET FORTH ABOVE ARE EXCLUSIVE AND IN LIEU OF ALL OTHERS, WHETHER ORAL OR WRITTEN, EXPRESSED OR IMPLIED CURRENT USA, INC. SPECIFICALLY DISCLAIMS ANY AND ALL IMPLIED WARRANTIES, INCLUDING BUT NOT LIMITED TO LOST PROFITS, DOWNTIME, GOODWILL, DAMAGE TO OR REPLACEMENT OF EQUIPMENT AND PROPERTY, AND ANY COSTS OF RECOVERING ANIMALS, PLANTS, TANKS OR OTHER AQUARIUM RELATED ITEMS AND/OR EQUIPMENT. CURRENT USA, INC. IS NOT RESPONSIBLE FOR SPECIAL, INCIDENTAL, OR CONSEQUENTIAL DAMAGES RESULTING FROM ANY BREACH OF WARRANTY, OR REPLACEMENT OF EQUIPMENT OR PROPERTY, OR ANY COSTS OF RECOVERING OR REPRODUCING ANY EQUIPMENT, ANIMALS OR PLANTS USED OR GROWN WITH CURRENT USA, INC. PRODUCTS. Some jurisdictions do not allow the exclusion or limitation of incidental or consequential damages or exclusions of implied warranties, so the above limitations or exclusions may not apply to you. This warranty gives you specific legal rights, and you may also have other rights that vary from jurisdiction to jurisdiction.